

# Hydraulic Pressure Switch PS-02 Series

# MAGNUM



## Features and Handling

- PS-02 is a spring loaded piston type pressure switch. The pressure of hydraulic oil acts on the piston in the pressure switch. The piston acts against the infinitely adjustable force of the spring which transfers the movement of the piston to the switch to open or close the electrical contact.
- Knob Set Screw is available for panel mounting.
- For installation, the pressure switch should be mounted in such a way as to prevent them being subject to vibration
- Pressure Difference 5%
- Electrical Rating DC 24V, AC 110-220V

## Ordering Code

PS-02 - 40 - 250

①

②

- ① Series PS-02
- ② Pressure Range (bar)  
15 - 100  
40 - 250

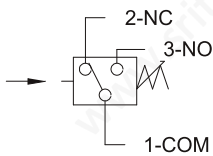

Graphic Symbol

## Dimensions mm (inch)

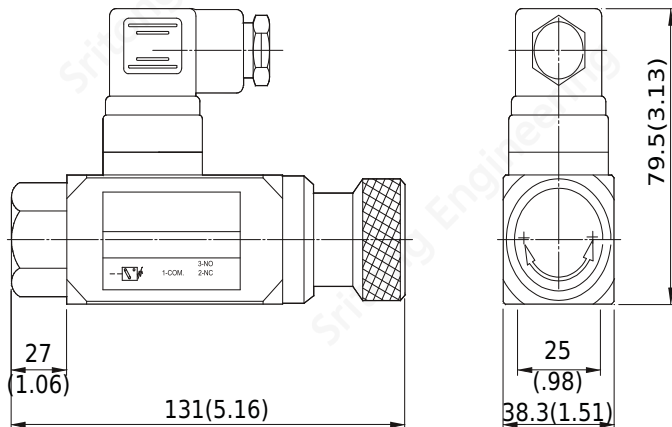

## Cross Sectional Drawing

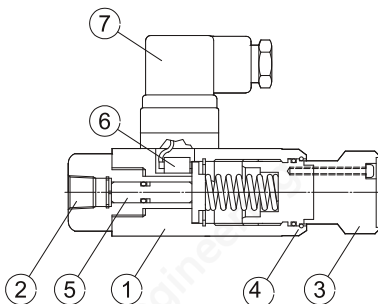

No.	Part Name
1	Body(Casting-Iron)
2	Connection Port 1/4"PT(Rc)
3	Pressure Adj. Knob
4	Knob Set Screw for panel
5	Servo-Piston
6	Micro-Switch
7	Electrical Connector