

閥類型符號 SYMBOL

MSCV-※

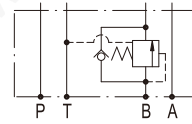

MSCV-02.03B

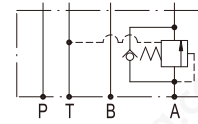

MSCV-02.03A

規格說明 SPECIFICATION :

型式 MODEL	最高使用壓力 MAX. OPERATING PRESSURE kgf/cm ²	壓力調整範圍 PRESSURE ADJ. RANGE kgf/cm ²	最大流量 MAX. FLOW l/min	重量 WEIGHT kg
MSCV-02-※	250	1 : 7-70 2 : 7-140 3 : 7-210	35	1.5
MSCV-03-※			70	4.0
MSCV-04-※			190	7.5
MSCV-06-※			300	14.0

型號說明 HOW TO ORDER :

MSCV - 02 - A - 3 - A - L

旋轉型式 KNOB TYPE
 無標示為K : 把手旋鈕螺桿調整 (標準型式)
 NO MARK FOR K : HAFT TURNING KNOB BOLT ROD ADJUST (STANDARD TYPE.)
 L : 內六角螺桿調整 INNER HEXANGULAR BOLT ROD ADJUST.

調整把手方向 DIRECTION OF KNOB
 A : A口側 A PORT SIDE
 B : B口側標準型 B PORT SIDE STANDARD TYPE

壓力調整範圍 PRESSURE ADJUSTING RANGE
 1 : 7-70 kgf/cm² 2 : 7-140 kgf/cm²
 3 : 7-210 kgf/cm²

口徑編號 SERIES NUMBER
 A : A PORT
 B : B PORT

閥規格 VALVE SIZE
 02 : 1/4" 03 : 3/8" 04 : 1/2" 06 : 3/4"

系列編號 SERIES NUMBER

單位UNIT : mm

安裝尺寸 INSTALLATION DIMENSIONS

MSCV-02

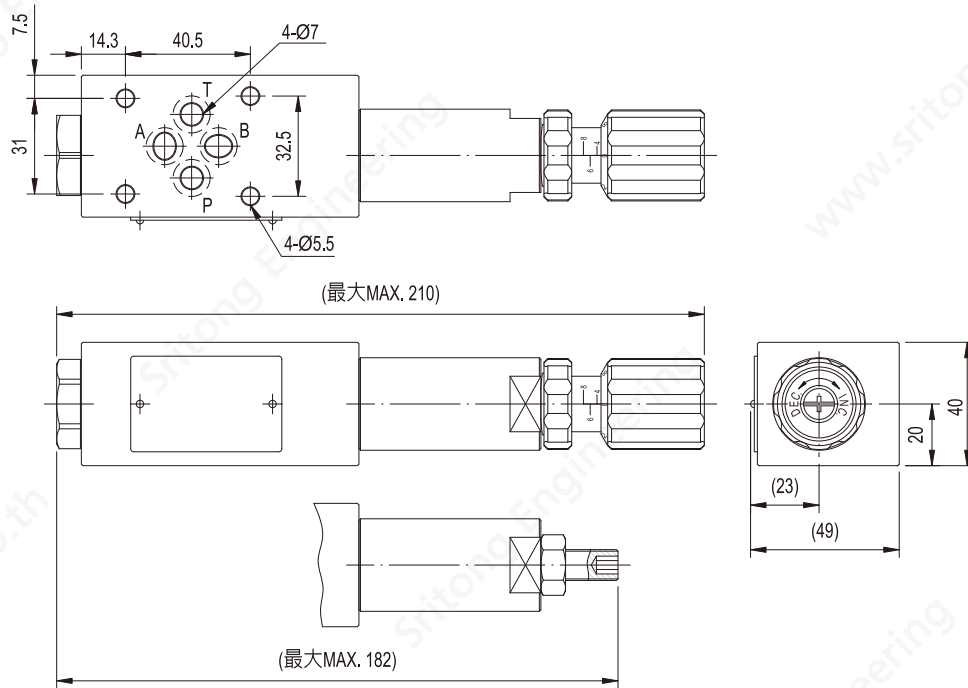

MSCV-03

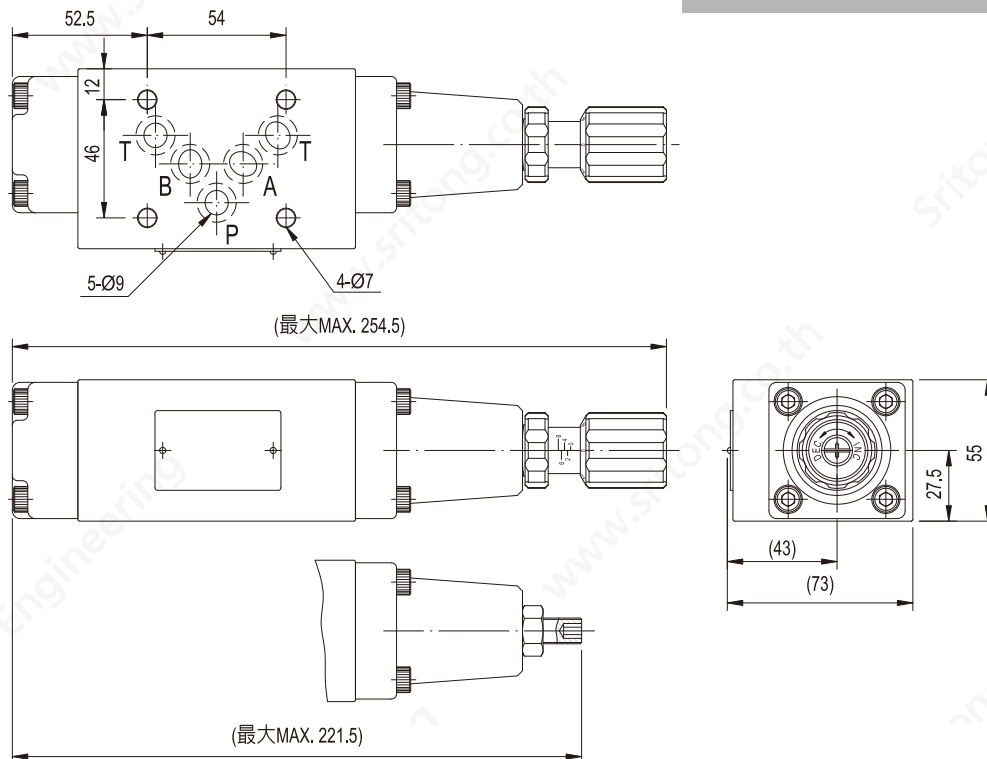

單位UNIT : mm

安裝尺寸 INSTALLATION DIMENSIONS

MSCV-04

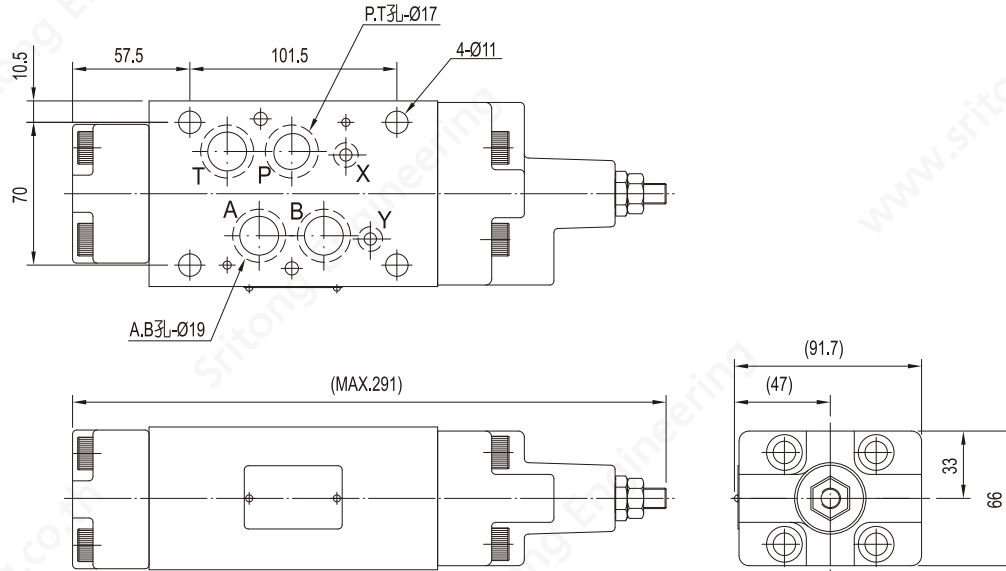

MSCV-06

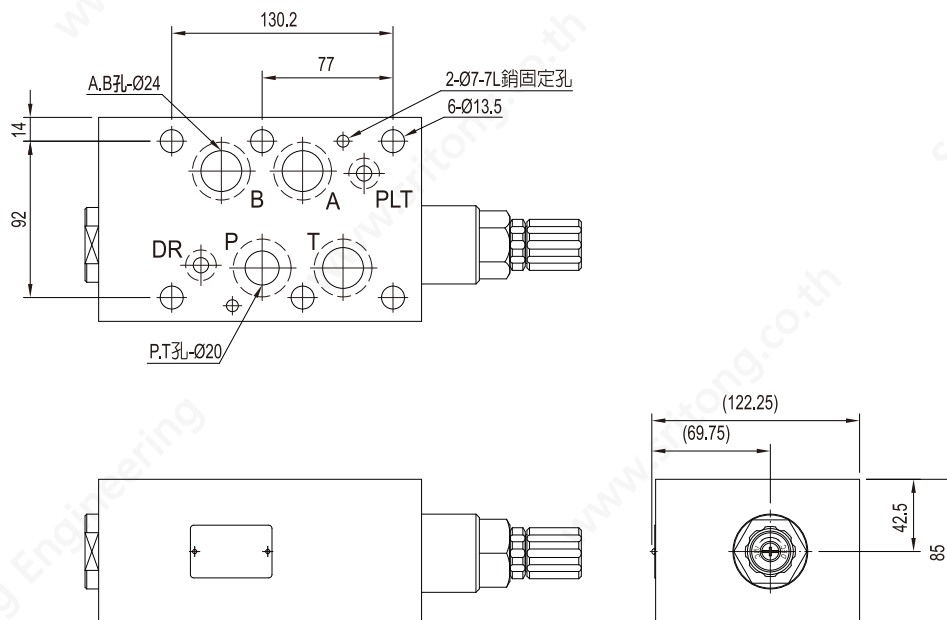

測試條件 PERFORMANCE CURVES

測試油黏度 TEST FLUID VISCOSITY : 35 cSt

測試油溫度 TEST TEMPERATURE : 50°C

● MSCV-02-A-B

自由流時壓力降特性 PRESSURE DROP FOR FREE FLOW

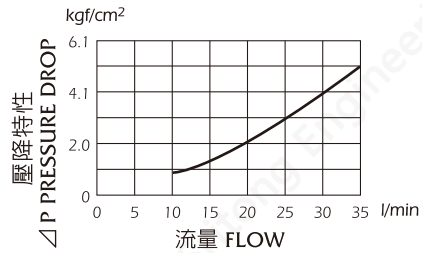

壓力降特性 PRESSURE DROP

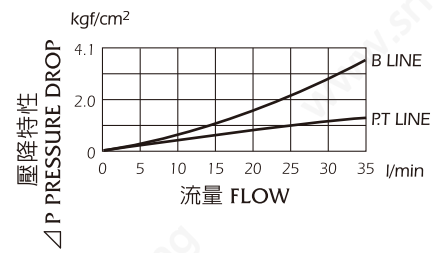

● MSCV-03-A-B

最低壓力調整特性 MIN. ADJ. PRESSURE

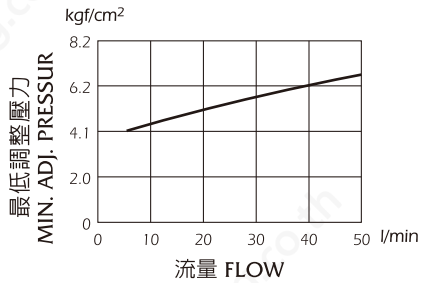

自由流時壓力降特性 PRESSURE DROP FOR FREE FLOW

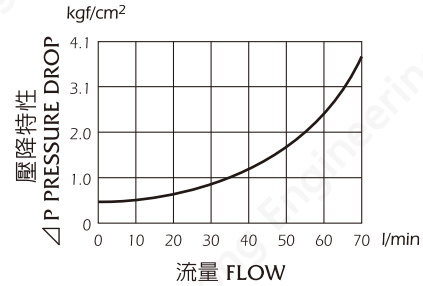

壓力降特性 PRESSURE DROP

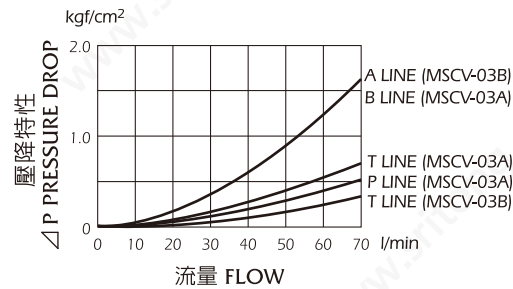

● MSCV-04-A-B

自由流時壓力降特性 PRESSURE DROP FOR FREE FLOW

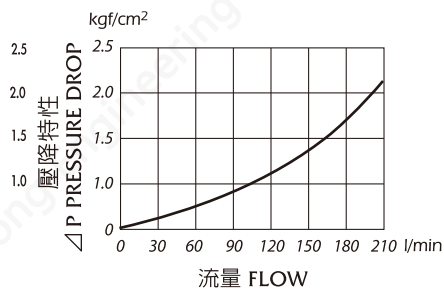

壓力降特性 PRESSURE DROP

