

閥類型符號 SYMBOL

MBRV-※

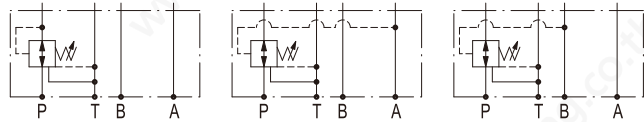

MBRV-02.03P

MBRV-02.03A

MBRV-02.03B

規格說明 SPECIFICATION :

型式 MODEL	最高使用壓力 MAX. OPERATING PRESSURE kgf/cm ²	壓力調整範圍 PRESSURE ADJ. RANGE kgf/cm ²	最大流量 MAX. FLOW l/min	重量 WEIGHT kg
MBRV-02-※	250	0 : 3-40	35	1.3
MBRV-03-※		1 : 7-70	70	3.5
MBRV-04-※		2 : 7-140	190	7
MBRV-06-※		3 : 7-210	300	11.6

型號說明 HOW TO ORDER :

MBRV - 02 - P - 3 - A - L

旋轉型式 KNOB TYPE
 無標示為**K**：把手旋鈕螺桿調整（標準型式）
 NO MARK FOR **K** : HAFT TURNING KNOB BOLT ROD ADJUST (STANDARD TYPE.)
L：內六角螺桿調整 INNER HEXANGULAR BOLT ROD ADJUST.

調整把手方向 DIRECTION OF KNOB
A：A口側 A PORT SIDE
B：B口側標準型 B PORT SIDE STANDARD TYPE

壓力調整範圍 PRESSURE ADJUSTING RANGE
0 : 3-40 kgf/cm² **1** : 7-70 kgf/cm²
2 : 7-140 kgf/cm² **3** : 7-210 kgf/cm²

口徑編號 SERIES NUMBER
P : P PORT **A** : A PORT
B : B PORT

閥規格 VALVE SIZE
02 : 1/4" **03** : 3/8" **04** : 1/2" **06** : 3/4"

系列編號 SERIES NUMBER

單位UNIT : mm

安裝尺寸

INSTALLATION DIMENSIONS

MBRV-02

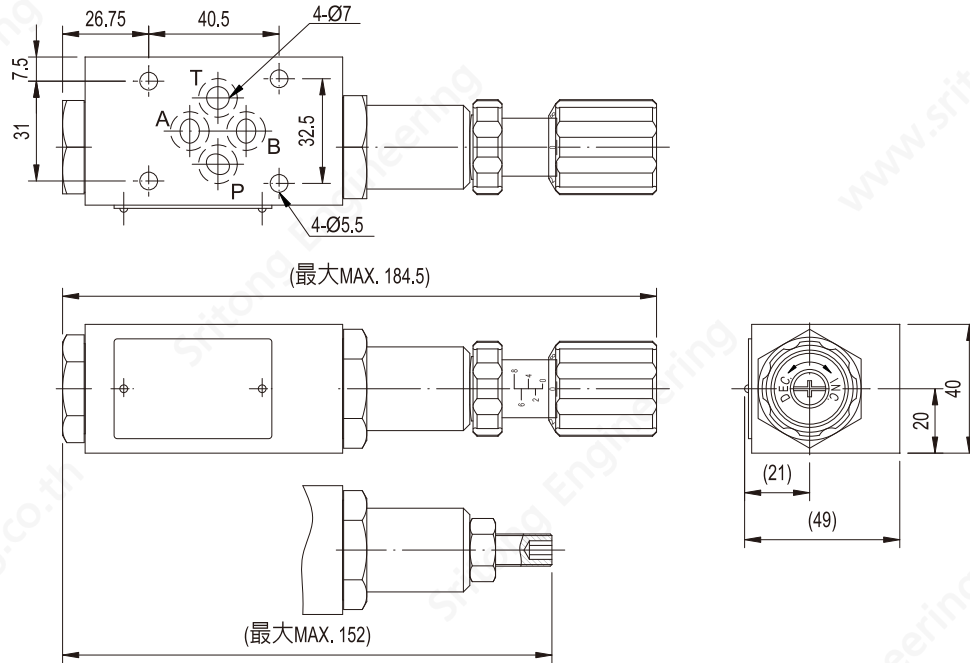

MBRV-03

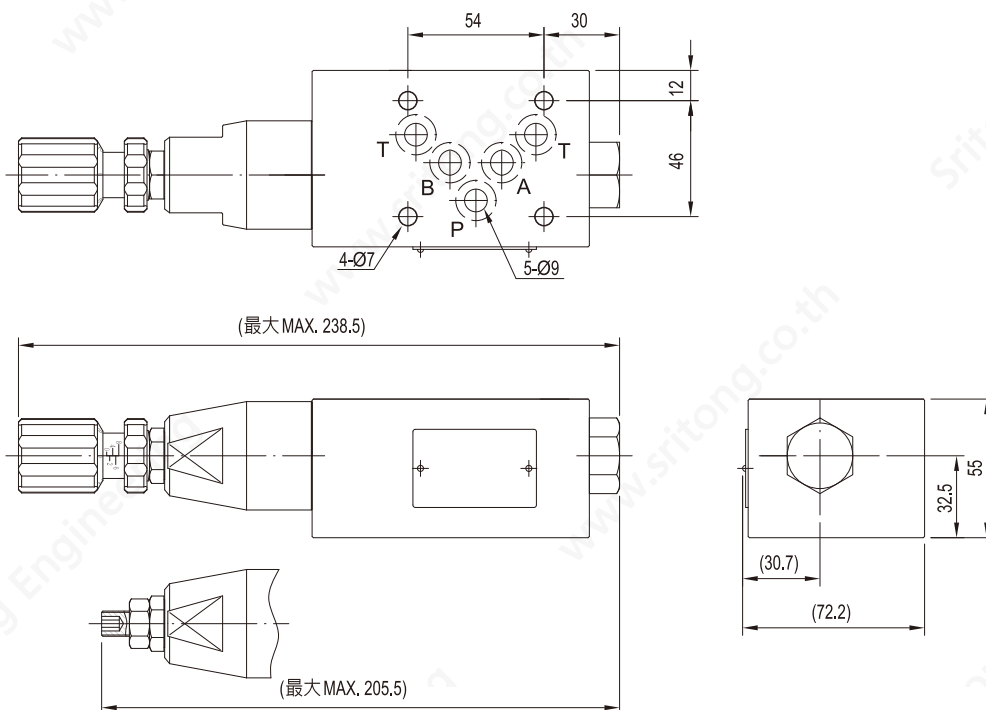

單位UNIT : mm

安裝尺寸 INSTALLATION DIMENSIONS

MBRV-03-※-10

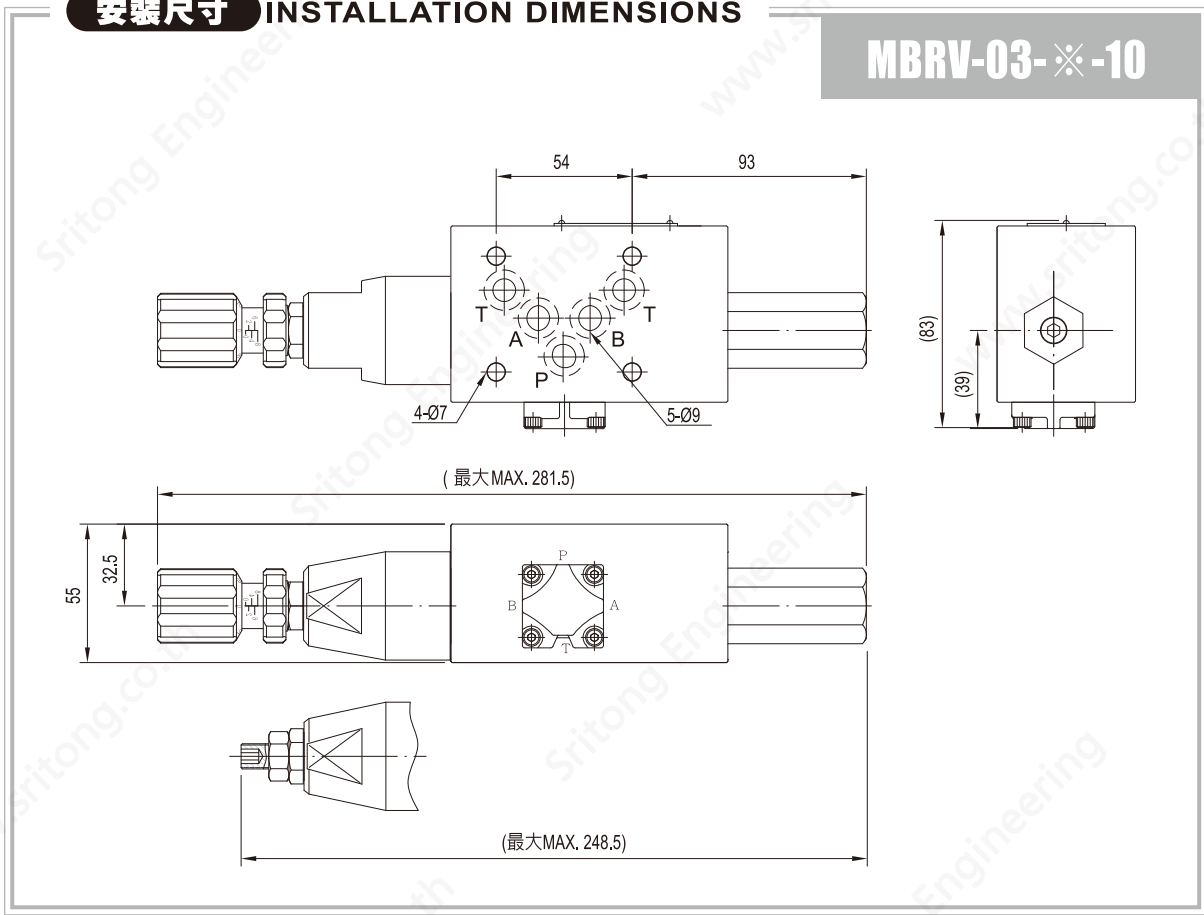

MBRV-04

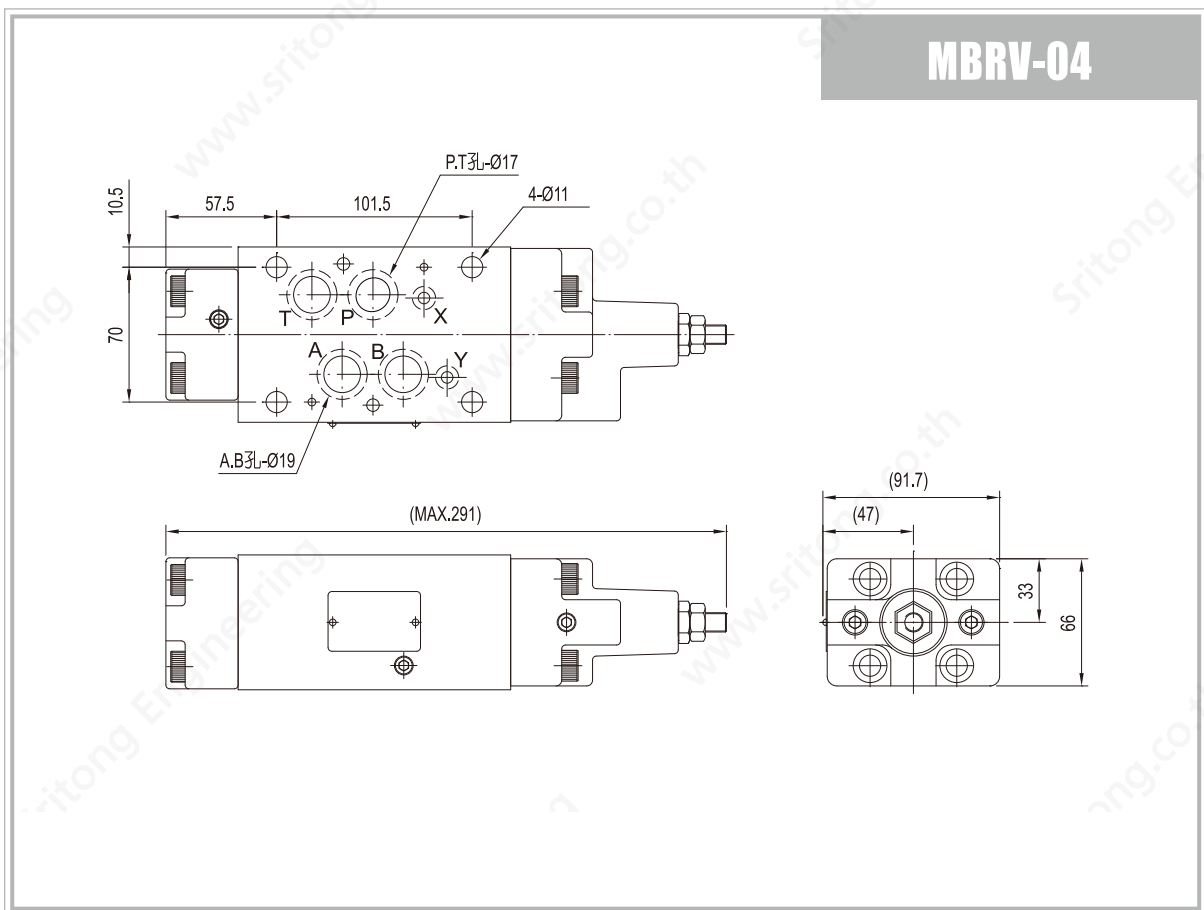

單位UNIT : mm

安裝尺寸

INSTALLATION DIMENSIONS

MBRV-06

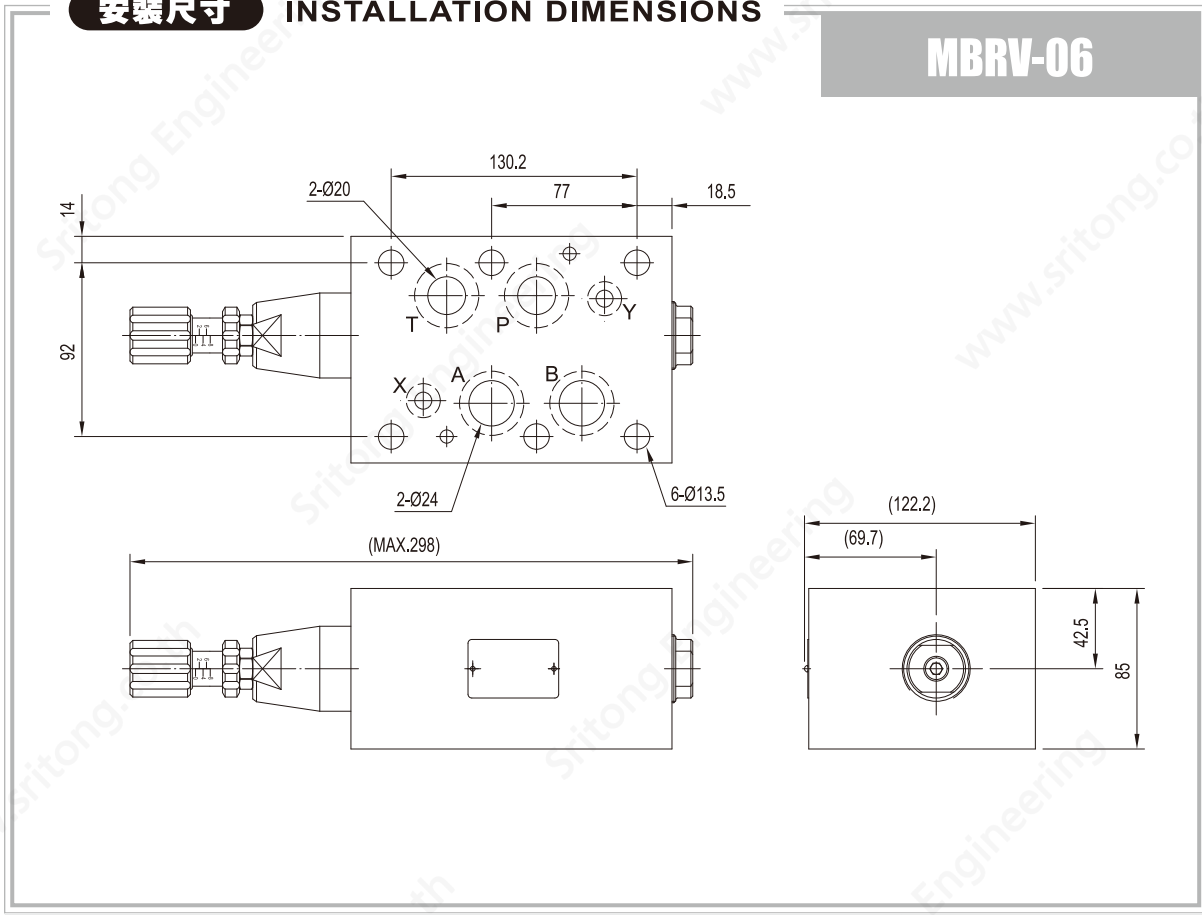

測試條件 PERFORMANCE CURVES

測試油黏度 TEST FLUID VISCOSITY : 35 cSt

測試油溫度 TEST TEMPERATURE : 50°C

● MBRV-02

壓降特性曲線 PRESSURE DROP

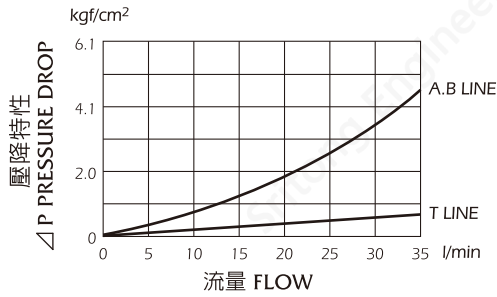

● MBRV-03

壓降特性曲線 PRESSURE DROP

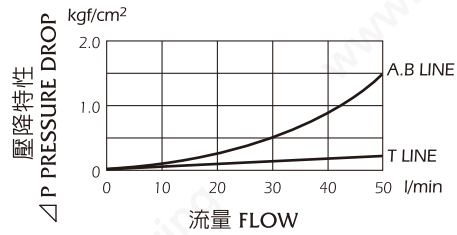

閥軸全開時壓力降特性 PRESSURE DROP AT SPOOL FULLY OPENED

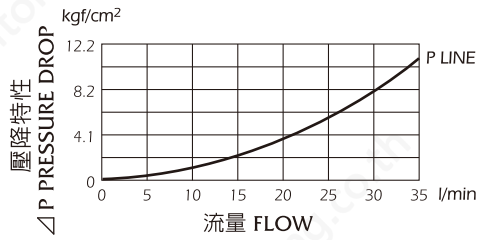

閥軸全開時壓力降特性 PRESSURE DROP AT SPOOL FULLY OPENED

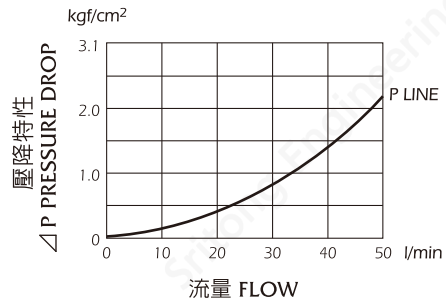

最低調整壓力—最大流量特性 MIN.ADJ. PRESSURE v.s. MAX. FLOW

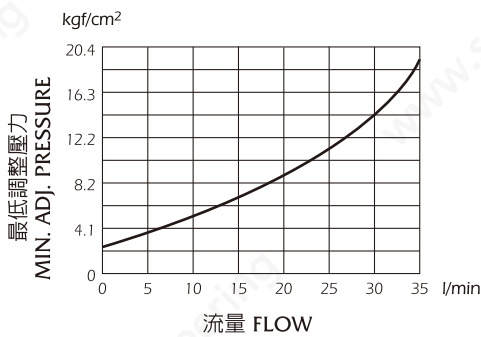

先導流量特性 PILOT FLOW

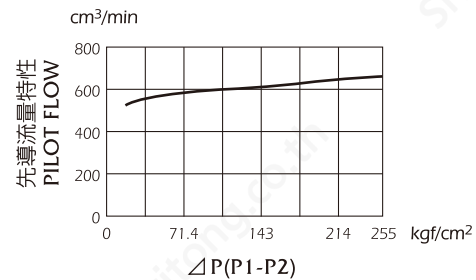

測試條件 PERFORMANCE CURVES

測試油黏度 TEST FLUID VISCOSITY : 35 cSt

測試油溫度 TEST TEMPERATURE : 50°C

● MBRV-04

壓降特性曲線 PRESSURE DROP

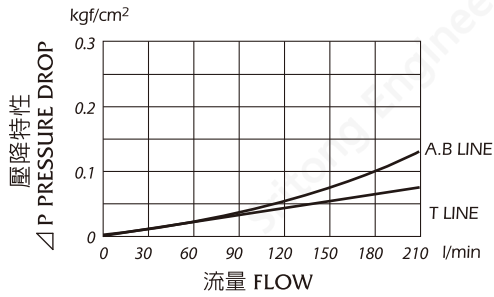

● MBRV-06

壓降特性曲線 PRESSURE DROP

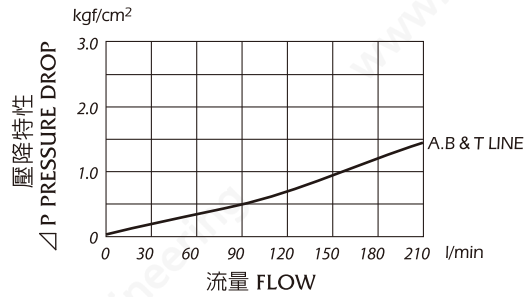

閥軸全開時壓力降特性 PRESSURE DROP AT SPOOL FULLY OPENED

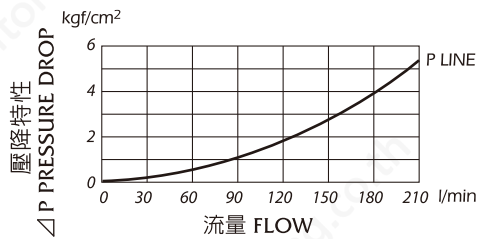

閥軸全開時壓力降特性 PRESSURE DROP AT SPOOL FULLY OPENED

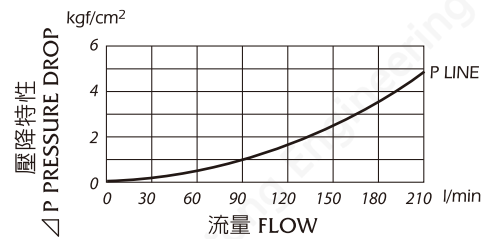

最低調整壓力—最大流量特性 MIN.ADJ. PRESSURE v.s. MAX. FLOW

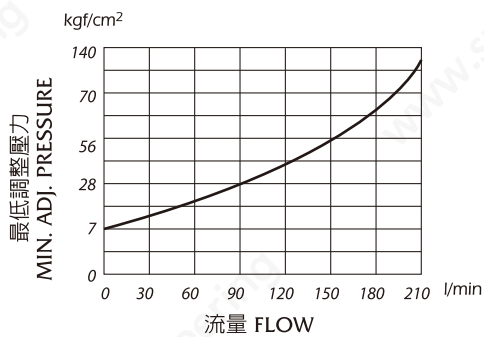

先導流量特性 PILOT FLOW

