

PLATE-FIN HEAT EXCHANGER

AH SERIES

Maximum dynamic pressure : 20 bar.

เพื่อป้องกันความเสียหายของแอร์คูลเลอร์ ต่อเชื้อควาส์หรือบายนพาสวาล์วทุกครึ่ง

AH	Thread	Flow	Capacity kcal/h	Hydraulic System	LxHxW m/m	Weight	Phase	Safety	Fan Dia.
	PT/PT"	L/min	$\Delta t=30^{\circ}\text{C}$	Hp		Kg		Reg.	m\m
AH0608T-CA*	3/4"	60	1,200	1~2	305x200x115	4.2	Single	CE	150
AH0608LT-CA*	3/4"	60	2,400	2~3	405x200x115	6	Single	CE	150x2
AH1012-CA*	1"	100	5,000	3~5	417x360x200	10	Single	CE,CCC	250
AH1012-3PCA*	1"	100	5,500	3~5	417x360x200	10	3	CE,CCC	250
AH1215-CA*	1"	100	7,000	5~7.5	510x390x210	15	3	CE,CCC	300
AH1417-A*	1"	100	9,000	7.5~10	570x411x200	11	Single		350
AH1418-CA*	1"	100	10,000	7.5~10	570x420x200	17	3	CE,CCC	350
AH1428-CA*	1 1/4"	180	13,000	15~20	570x420x230	21	3	CE,CCC	350
AH1470-A*	1 1/4"	180	11,000	10~15	570x407x225	13	Single		350
AH1470-CA*	1 1/4"	180	13,000	15~20	520x475x320	25	3		350
AH1490-CA*	1 1/2"	200	16,000	20~25	520x640x300	30	3	CE,CCC	350
AH1680-CA*	1 1/2"	200	21,000	25~40	520x640x320	35	3	CE,CCC	400
AH1890-CA*	1 1/2"	200	25,000	30~50	650x800x380	52	3	CE,CCC	450
AH2342-CA*	1 1/2"	200	37,000	50~75	605x935x543	80	3	CE	560
AH2583-CA*	RP1 1/2"	300	50,000	75~100	645x950x630	100	3	CE	630
AH2890-CA*	1 1/2"	300	60,000	100~125	875x1000x900	150	3	CE	700
AH3-2583-CA*	1 1/2"	300	140,000	300	875x2400x700	300	3	CE	630x3

AW Series สำหรับวงจรที่ใช้ปั๊มลูกสูบแบบปรับค่าได้ โดยต่อที่ท่อเดรนเท่านั้น

AW	Thread	Flow	Max. Pressure	Capacity kcal/h	LxHxW m/m	Weight	Phase	Safety	
	PT/PT"	L/Min	BAR	$\Delta t=30^{\circ}\text{C}$		Kg		Reg.	
AW0607-CA*	1/2"	20	15	700	250x200x108	3.3	Single	CE,CCC	
AW0608-CA*	1/2"	20	15	900	310x200x108	3.7	Single	CE,CCC	
AW0608L-CA*	1/2"	20	15	1500	410x200x108	5.2	Single	CE,CCC	

AL Series ไม่สามารถใช้กับวงจรที่ความดันกระชากได้

สำหรับวงจรที่ใช้ปั๊มใบพัดแบบปรับค่าได้ ที่ความดันไม่เกิน 70 bar โดยต่อที่ท่อเดรนเท่านั้น

AL	Thread	Flow	Max. Pressure	Capacity kcal/h	LxHxW m/m	Weight	Phase	Safety	
	PT/PT"	L/Min	BAR	$\Delta t=30^{\circ}\text{C}$		Kg		Reg.	
AL404	1/2"	10	10		250x203x67	1			
AL404-A*	1/2"	10	10	1100	250x203x120	2.25	Single		
AL404-CA*	1/2"	10	10	1200	250x203x120	2.85	Single	CE,CCC	
AL404-4A*	1/2"	10	10	800	250x203x98	1.75	Single		
AL608	3/8"	10	10		250x203x57	0.75			
AL608-A*	3/8"	10	10	800	250x203x110	2	Single		
AL608-CA*	3/8"	10	10	900	250x203x110	2.6	Single	CE,CCC	
AL608-4A*	3/8"	10	10	600	250x203x88	1.5	Single		
AL190	3/8"	10	10		220x167x56	0.5			
AL609	1/2"	10	10		250x203x57	0.75			

Calculation Of Air-Oil Heat Exchanger Installed On Hydraulic System

Introduction :

First of all, the choice of cooling system needs finding out the heat quantity of the hydraulic system, and furthermore we can design the appropriate cooling mode and ability for the requirements of clients.

The quantity of producing heat on hydraulic system cannot be estimate by calculation, because of the different of components and elements, using frequency and the design of circuit make this impossible.

1. Choosing the cooler rely on flow rate is only a basic condition, because we choice the input motor horse power by considering the pressure of pump and flow rate in the meantime.
2. The selecting of cooler depended on the quantity of producing heat matches up with the cooling capability on the system.
3. According to the actuality experience, we could count up the appraised value by inputting 70% electricity energy into the heat quantity.(Different engineer and elements make this different.)
4. If we using more delicate components and less heat quantity product, then the 70% heat quantity could be lower to 60% or much lower. Please confirm to your distributor.
5. If there is hydraulic motor in the circuit, then we should calculate the heat quantity up to 100%.

Data required

1.Simplify

Contrast the Input horse power with hydraulic horse power in the performance table, and you could find out the applicable cooler.

2.Calculate

N =installed power in the system (kW)

Q =heat to be dissipated (kcal/h)

T_o =maximum allowed oil temperature ($^{\circ}C$)

T_{amb} =ambient temperature ($^{\circ}C$)

Kr : Means the required specific performance of the heat exchanger

$Kr=Q/\Delta$, dove ΔT is the difference between oil inlet temperature and summer ambient temperature, while Q is the quantity of heat to be dissipated which can be easily calculated considering 60-100% of installed power.

Example (hydraulic) :

$N=20$ kW $T_o=50^{\circ}C$ $T_{amb}=35^{\circ}C$

$Q=70\% \times 20 \text{ kW} = 14 \text{ kW} = 12040 \text{ kcal/h}$ (1 kW=860 kcal/h)

$\Delta T=50-35=15^{\circ}C$

$Kr=12040 \text{ kcal/h} \div 15^{\circ}C = \underline{802 \text{ kcal/h}^{\circ}C} = \underline{0.93 \text{ kw}^{\circ}C}$

The choice of the correct cooler is made by using the diagrams.
You will find in our technical catalogues.

Equivalents among main units

1HP = 635kcal/h

1kW = 860 kcal/h

1 cSt = 1 mm²/ sec

1 BTU = 0.35 kcal/h

1 cSt = 1mm²/sec

1 bar = 100kpa

AL608

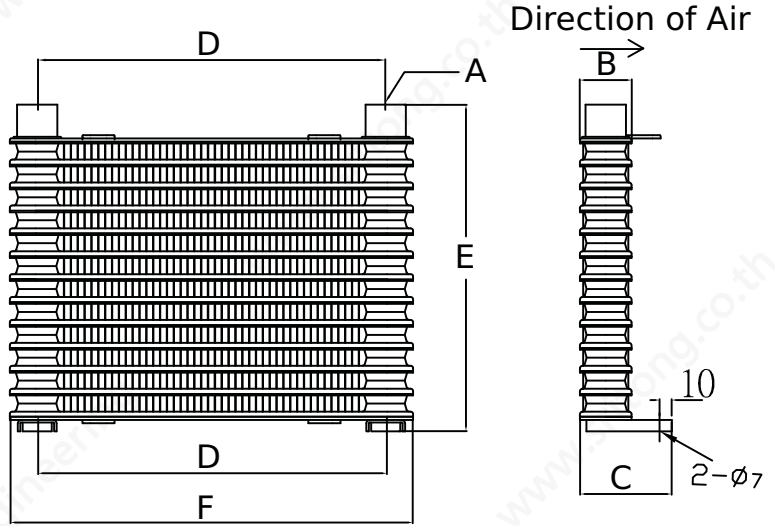

LOSE OF PRESSURE DIAGRAM (32 CST)

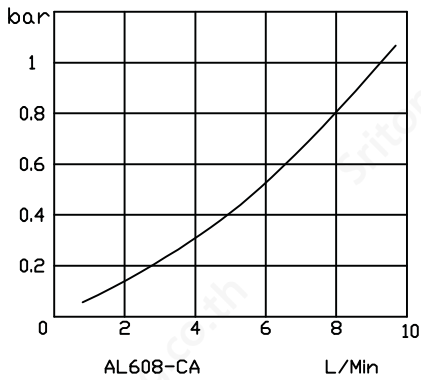

	管牙 A PT/RC	B	C	D	E	F	WEIGHT Kg
AL608	3/8"	32	56	217	203	250	0.75
AL404	1/2"	42	66	217	203	250	1
AL190	1/2"	32	56	190	167	220	0.5
AL609	1/2"	32	56	217	203	250	0.75

AL608-CA

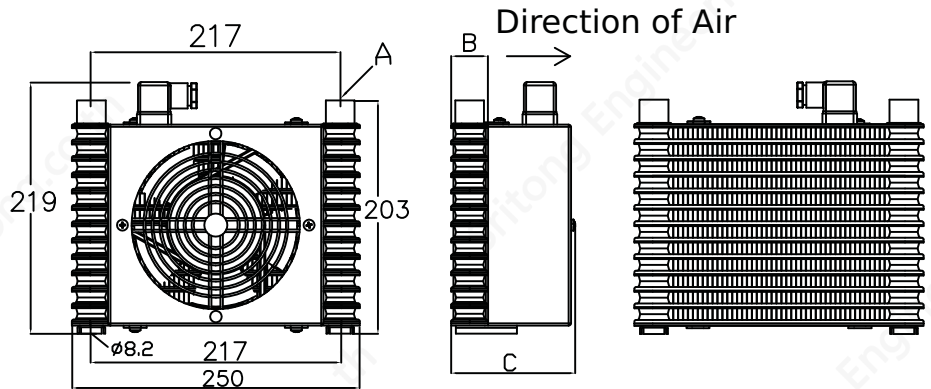

PERFORMANCE DIAGRAM

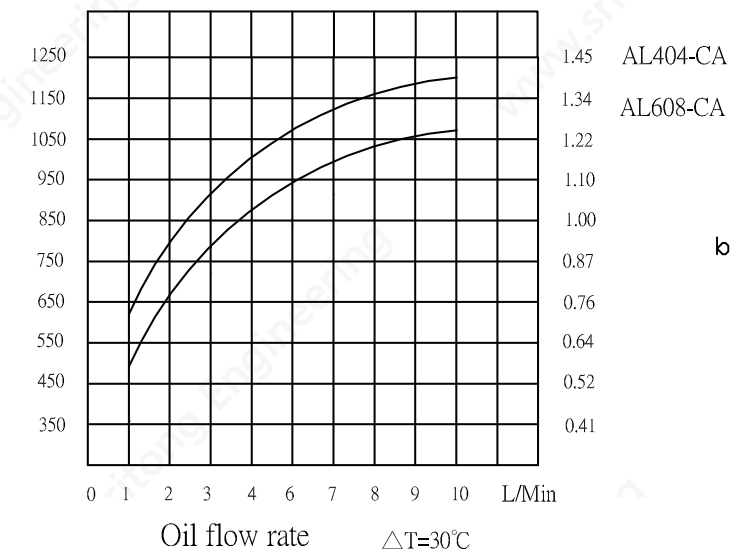

型 式	A PT/RC	B	C	WEIGHT
AL608-CA	3/8"	32	120	2.6
AL404-CA	1/2"	42	110	2.25
AL609-CA	1/2"	32	120	2.6

LOSE OF PRESSURE DIAGRAM (32 CST)

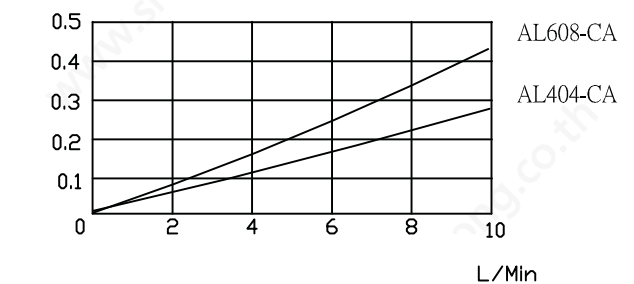

AW608-CA

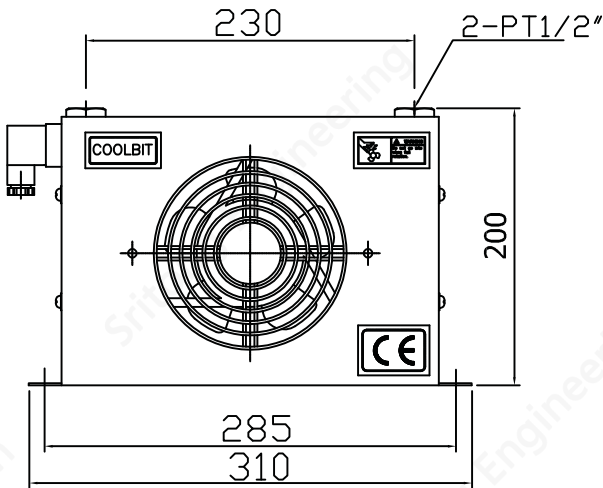

Direction of air
→

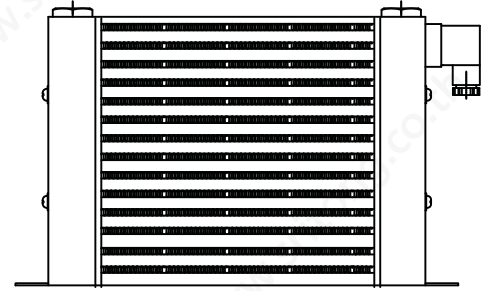
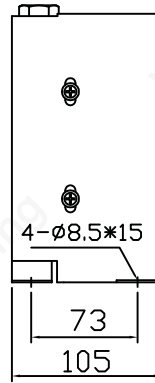

$kn \left[\frac{kcal}{h} \right]$ PERFORMANCE DIAGRAM

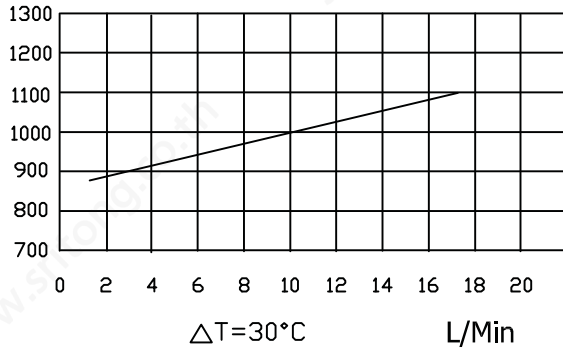

LOSE OF PRESSURE DIAGRAM (32 CST)

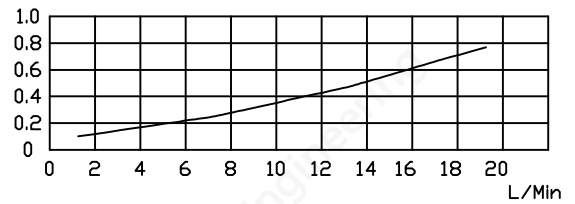

AW608L-CA

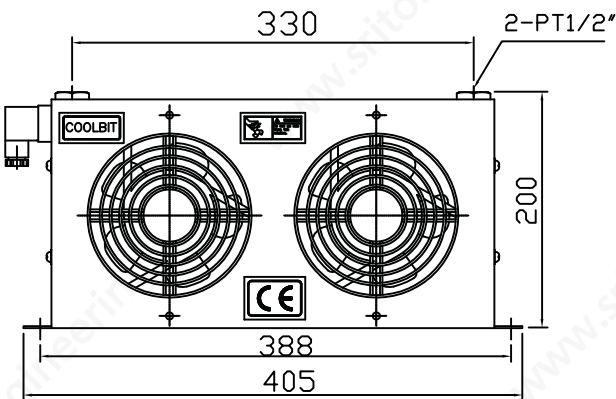

Direction of air
→

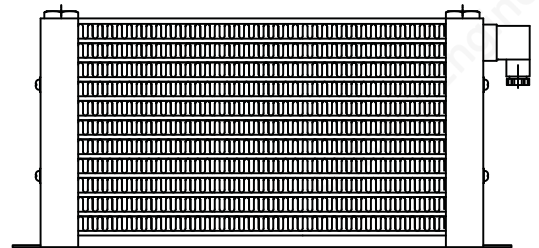
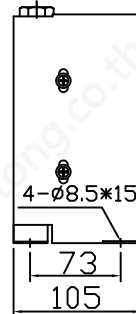

$kn \left[\frac{kcal}{h} \right]$ PERFORMANCE DIAGRAM

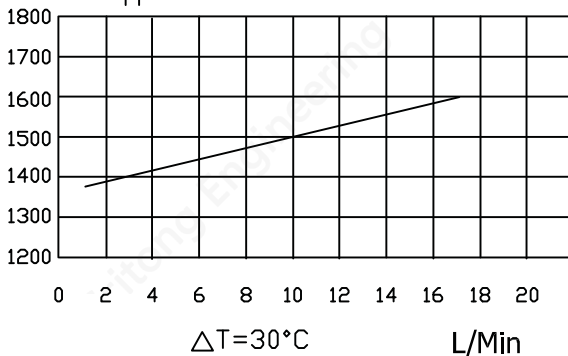

LOSE OF PRESSURE DIAGRAM (32 CST)

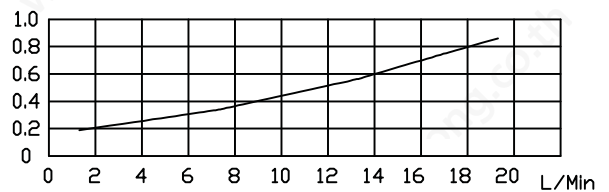

AH0608T-CA*

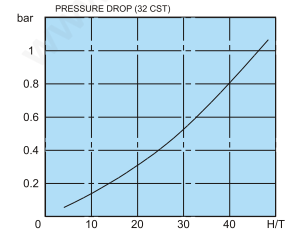
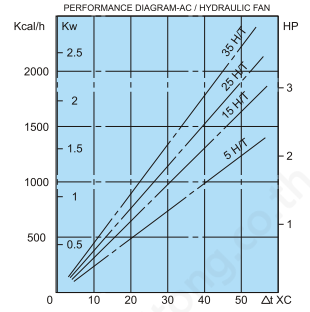
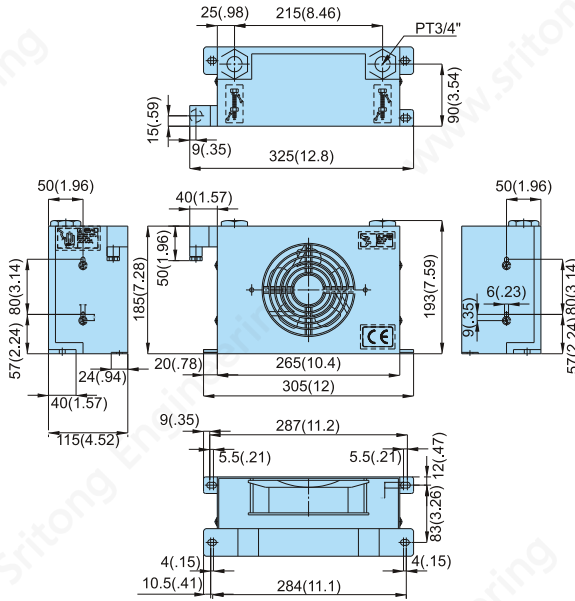
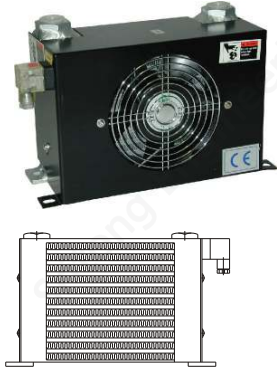

AH0608LT-CA*

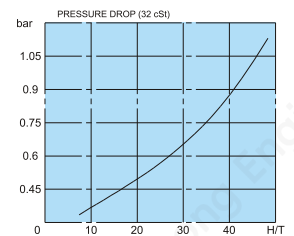
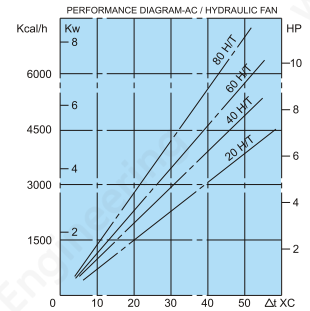
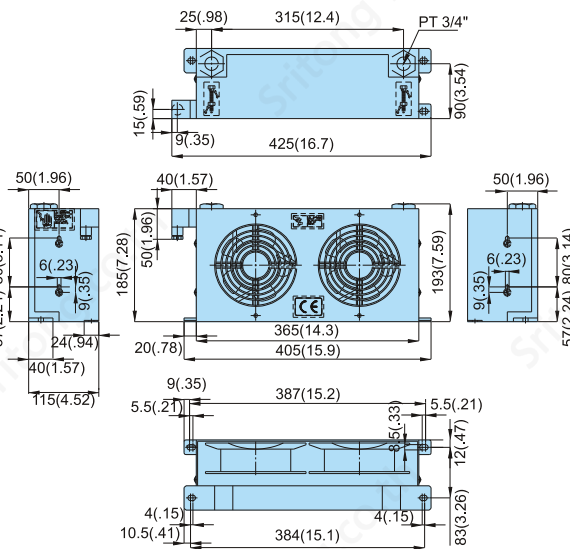
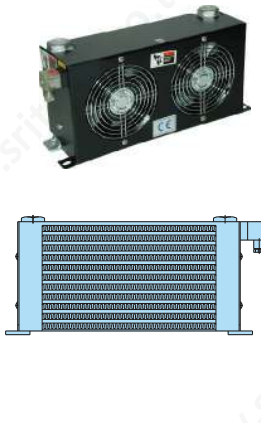

AH1012-CA*

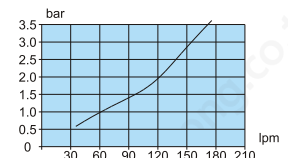
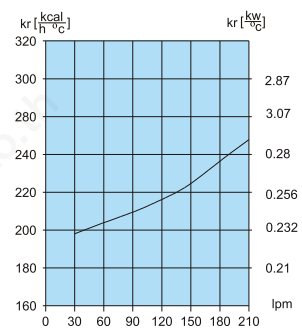
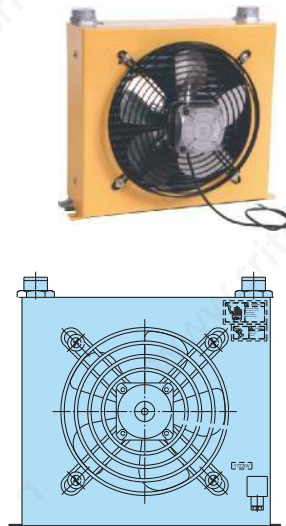
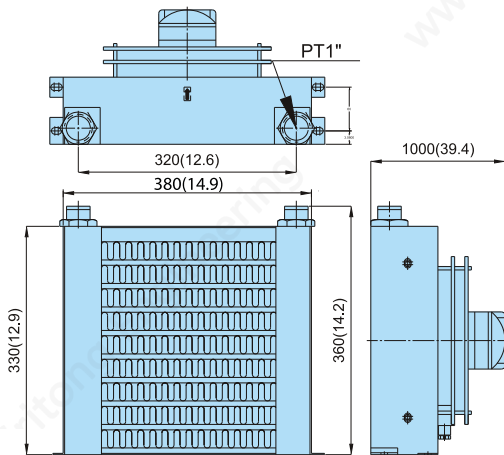

PLATE-FIN HEAT EXCHANGERS

AH1417-A*

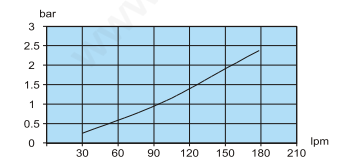
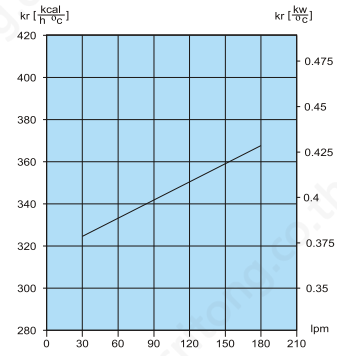
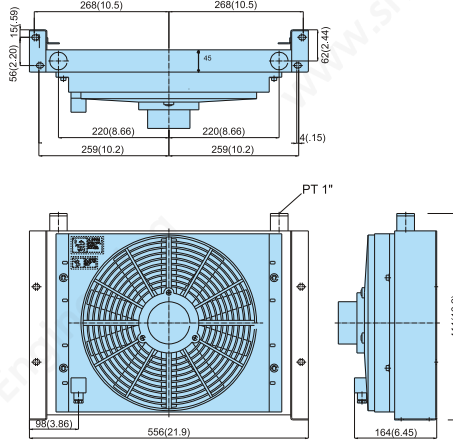
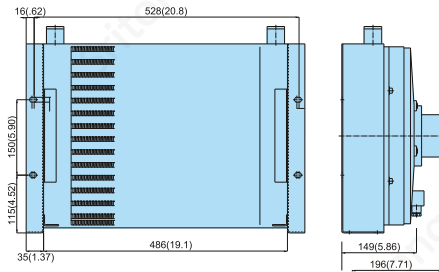

PLATE-FIN HEAT EXCHANGERS

AH1470-A*

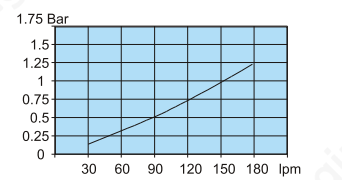
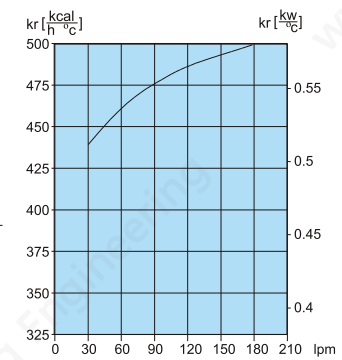
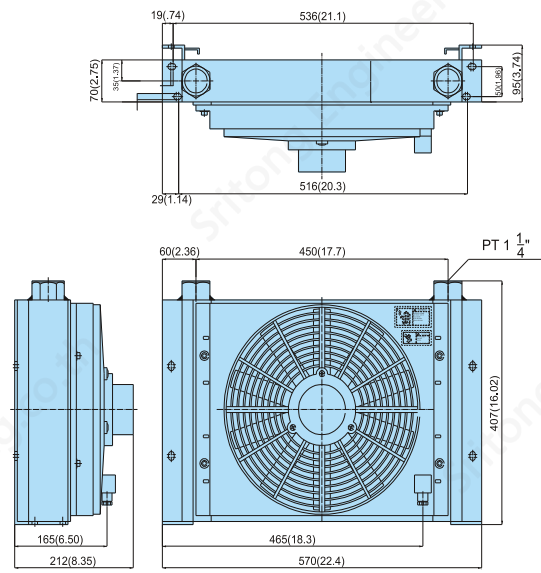
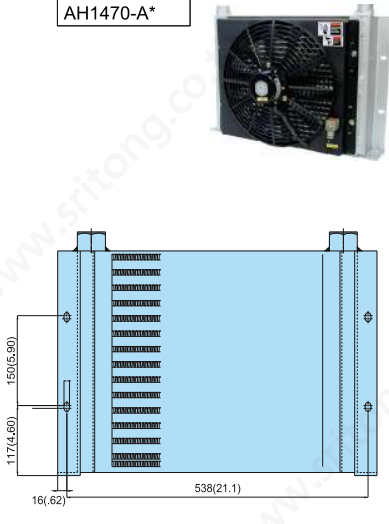

PLATE-FIN HEAT EXCHANGERS

AH1470-CA*

